



## LIFT-112

### 6" Drop Spindle Lift Kit

### E-Z-Go RXV Gas and Electric March 2013+

### Installation Instructions

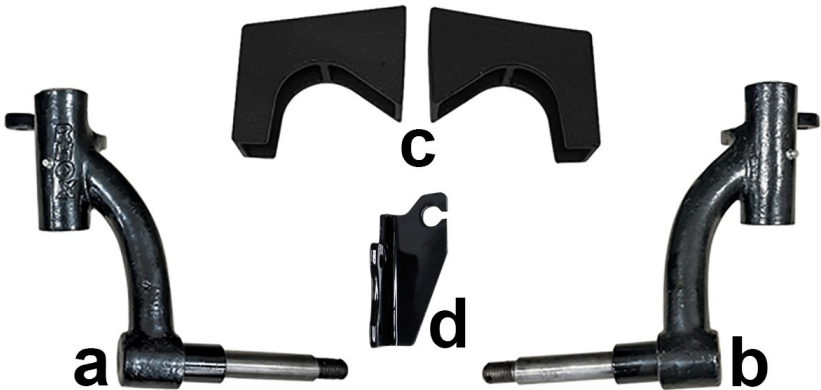

Contents of LIFT-112 E-Z-Go RXV Lift Kit:

- a (1 ea.) Driver Side Spindle
- b (1 ea.) Passenger Side Spindle
- c (2 ea.) Rear Lift Blocks
- d (1 ea.) Brake Cable Bracket
- e (1 ea.) Box of Hardware (Contents on Next Page)

**Caution:** Please read through the instructions carefully. Installer is responsible for damage if instructions are not followed properly. An extra installer may be helpful in some parts of the installation. Please refer to maintenance manual for all torquing specifications.

**Note:** You must install larger tires and wheels once the cart is lifted. Stock wheels will not work. We recommend at least a 10" wheel with a minimum of a 1" offset for use on the RHOX Lift Kit.

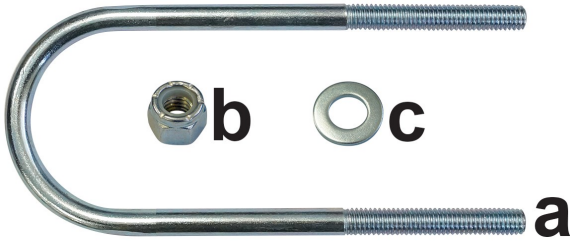

Contents of LIFT-112 Hardware Kit		Qty.
a	3/8-16 U-Bolts	4
b	3/8-16 Nylock Nuts	8
c	3/8" Flat Washers	8

Tools Needed for Installation

- Sockets & Wrenches (9/16", 15mm, 5/8", 3/4", 17mm, 15/16")
- Flat Head Screwdriver
- Rubber Mallet
- Tie Rod Separator
- Grease Gun
- Tape Measure

Front Suspension Installation (Front of the Cart)

1. Engage parking brake.
2. Turn key OFF.
3. Place Tow/Run Switch in TOW if equipped.
4. Chock the back of the rear wheels.
5. Remove the hub caps (if any). Loosen the lug nuts on both front wheels but do not remove them.
6. Place a jack under the front chassis. Lift the cart high enough to accommodate the new tires and wheels.
7. Place (2) jack stands securely under the chassis and remove the jack.
8. Fully remove the (8) front lug nuts, tires and wheels.

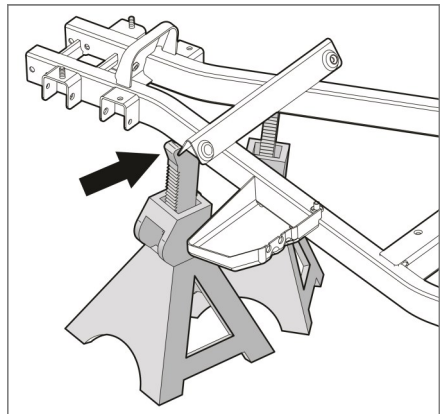
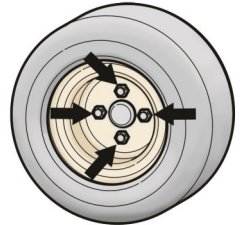

9. Remove dust covers (black arrow), nuts (green arrow) and wheel hubs (red arrow) from both spindles. Retain all three components.

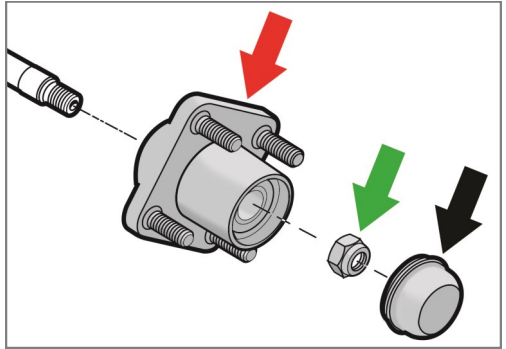

10. Disconnect the tie rod ends from the spindles (black arrow). Retain hardware.

**NOTE:** Use a tie-rod separator to remove the tie-rod end from the spindle. Do not hammer the stud as it will damage the threads.

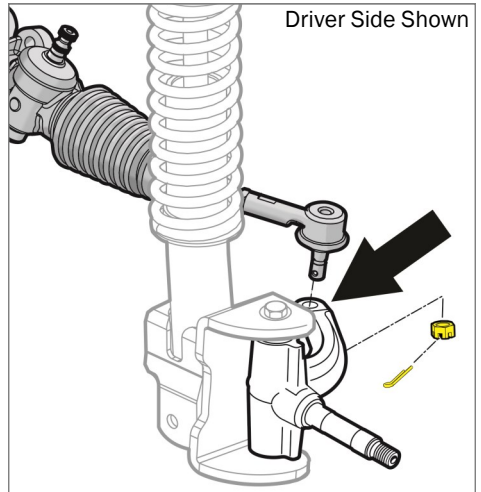

11. Disconnect the spindles from the shocks. Retain all hardware, sleeves and bushings.

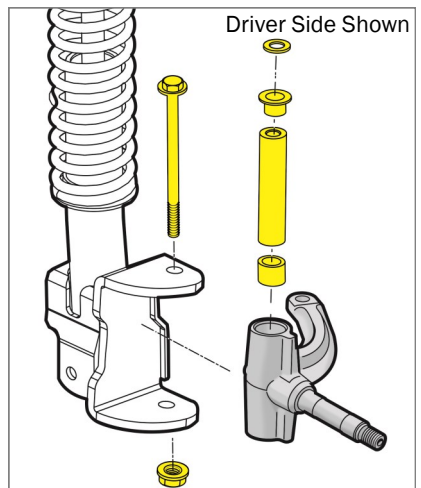

12. Install the new spindles where the original ones were removed using the Original Hardware.

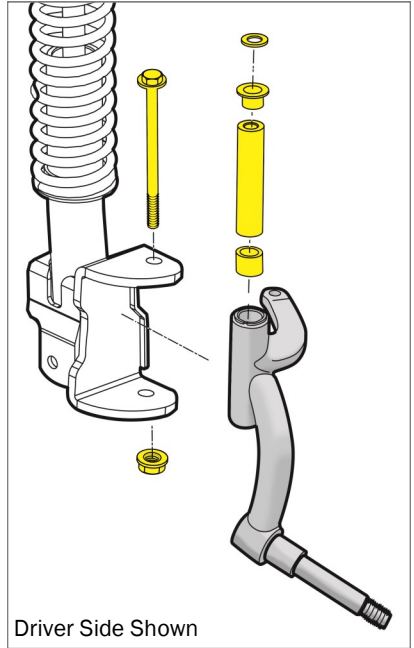

13. Attach the tie-rods to the new spindles using the Original Hardware.
14. Grease the fittings on both spindles using a general purpose automotive grease.
15. Tighten any hardware left loose in this section.
16. Reinstall the hubs and dust caps that were removed on page 3 using the Original Hardware. Hand tighten.
17. Install the (2) front tires and wheels. The stock tires and wheels will not work on the newly lifted cart. Fully tighten the lug nuts on both wheels.

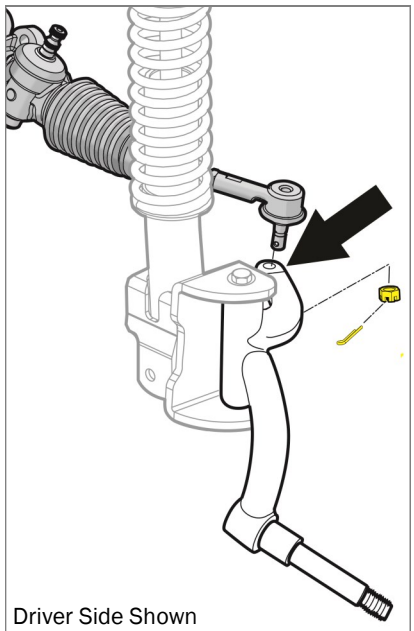

**NOTE:** It is recommended to use a wheel with at least a 1" offset.

18. Once the tires and wheels are fully secure, place the jack under the cart. Remove the jack stands and lower the cart. Remove the chocks behind the rear wheels.

**NOTE:** Toe adjustments will be made at the end of the installation.

### Rear Suspension Installation (Rear of the Cart)

**Safety Note:** Proper eye and mouth protection should be worn during this section to protect the installer from falling debris when working under the cart.

The rear axle is only secured in place by the leaf springs, U-bolts and the jack. For safety reasons, only complete one side of the suspension at a time.

1. Engage parking brake.
2. Turn key OFF.
3. Place Tow/Run Switch in TOW if equipped.
4. Chock the front of the front wheels.
5. Remove the hub caps (if any). Loosen the lug nuts on both rear wheels but do not remove them.
6. Place a jack securely under the rear axle. Safely lift the rear end of the cart enough to accommodate the additional height of the larger tires and wheels.

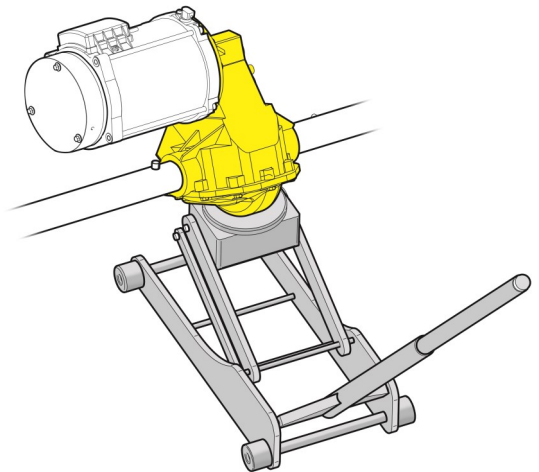
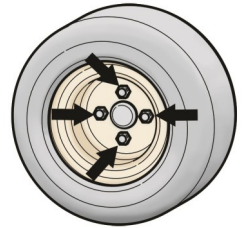

7. Place jack stands under the chassis on both sides of the cart to stabilize it. DO NOT remove the jack.
8. Fully remove the (8) rear lug nuts, tires and wheels. Discard.
9. Disconnect the bottom of the passenger side shock from the shock mounting plate (black arrow, page 6). Push the shock upward and out of the way. Retain hardware.

10. With the axle supported by the jack, remove the (2) U-bolts holding the passenger side rear axle, leaf spring and shock mounting plate (red arrows). Remove and discard the U-bolts. Retain shock mounting plate.

**CAUTION:** Complete one side at a time.

11. Disconnect the passenger side leaf spring from the rear shackle (green arrow). Retain hardware.
12. Disconnect the front portion of the leaf spring from the front shackle (blue arrow). Retain hardware and remove leaf spring.
13. Carefully lower the rear axle away from the chassis with the jack. The jack stands will remain in place to support the chassis.
14. Place the leaf spring over top of the axle. Reconnect the leaf spring to the front shackle using the Original Hardware (blue arrow, page 7).

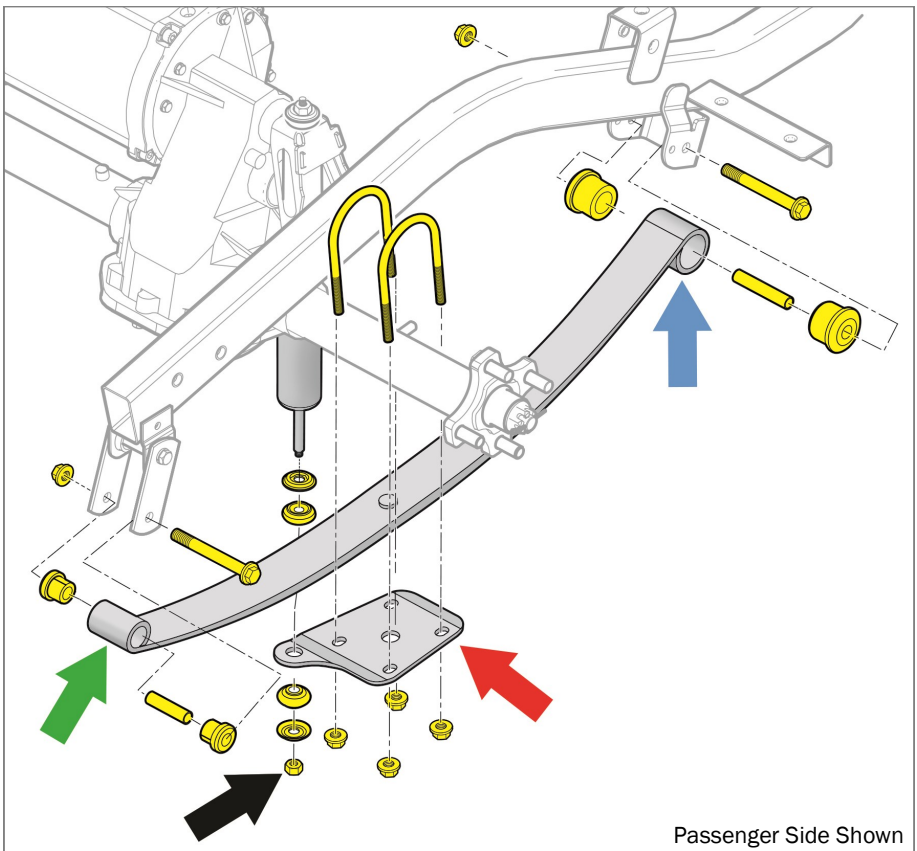

15. Orient the lift block as shown. Place the lift block between the axle and the leaf spring. The forward facing hole will line up with the alignment pin on the axle. The alignment pin on the leaf spring will seat in the top hole of the lift block.

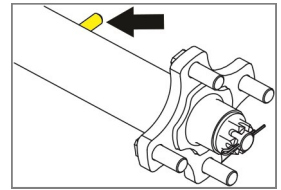
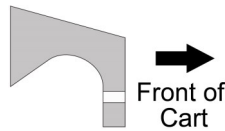

16. Place the original shock mounting plate on top of the leaf spring (red arrow). The alignment pin on the leaf spring will seat in the center hole of the shock plate.
17. Fasten the shock plate, leaf spring and lift block to the axle with (2) 3/8-16 U-Bolts, (4) Flat Washers and (4) Nylock Nuts. Hand tighten U-bolts evenly on both sides.
18. Repeat steps 9-17 on the driver side.

**NOTE:** If the driver side brake cable is mounted on top of the axle, swap the OE brake cable bracket with the new one included in this kit.

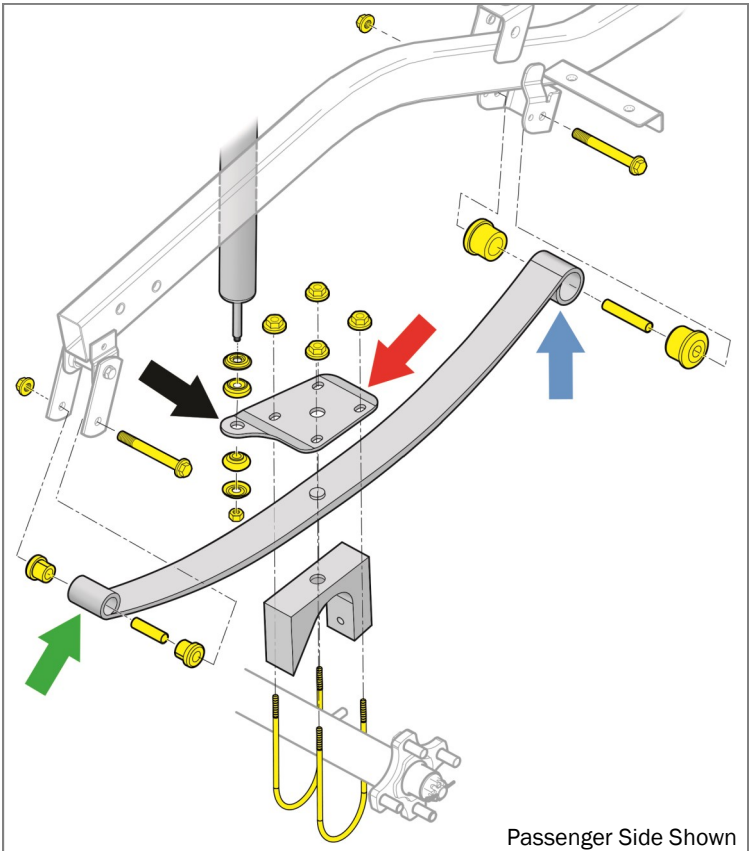

Passenger Side Shown

19. Using the jack, safely lift the rear axle and guide the rear portion of the leaf springs to their original positions. Reinstall the leaf springs to the rear shackles (green arrow, page 7) using the Original Hardware removed in step 11.
20. Fasten the shocks to the shock mounting plates (black arrow, page 7) using the Original Hardware.
21. Install the (2) new rear tires/wheels on the rear hubs. Remove the jack stands and lower the cart. Remove the jack.

Adjust the Toe

1. Drive forward and back 20-40 feet to check the toe before making adjustments. Only make adjustments if needed.

For stability, an 1/8" toe-in with a positive camber is recommended. This will level out when the cart is loaded.

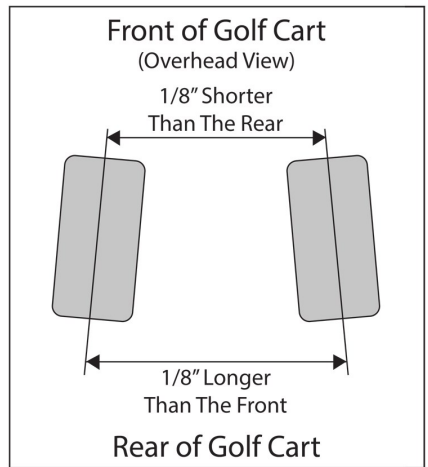

Toe-In Adjustment

2. Adjust the toe by loosening the jam nut on the tie rod. Turn the hex piece to adjust. Adjustments should be made evenly on both sides. Shortening the tie rods increases the toe, lengthening decreases it.
3. Once the desired toe is reached, tighten the jam nuts on the tie rods.

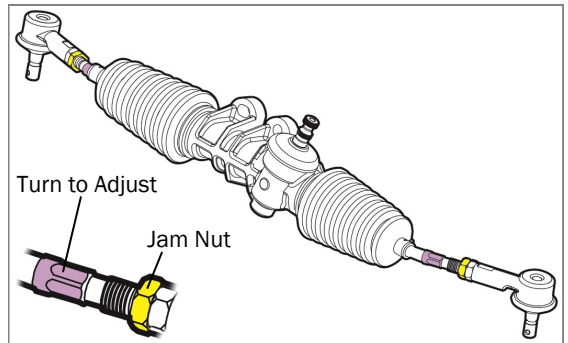

This completes the installation of your RHOX Lift Kit.  
 Please enjoy safely! Scan QR code or use the link to view the installation video.  
<https://vimeo.com/user39935056>

